



# MULTISPAN

## User Manual

### MS-1248-M1



**Multispan Control Instruments Pvt Ltd**

72/B, Phase 1, GIDC Estate, Vatva, Ahmedabad-382445, Gujarat, India.

✉ export@multispanindia.com ☎ +91-9978991483

🌐 www.multispanindia.com

## Technical Specification

### INPUT:

	Input	Range
Input Types	J	0 to 600 °C
	K	0 to 1200 °C
	PT-100	-99 to 400 °C
	PT.1	-99.0 to 400.0 °C
Resolution	J,K,PT-100,PT.1 = 1 °C	
Indication	±1% of FSD ± 1 °C	
Accuracy	(FSD:- full scale deflection)	

### DISPLAY, KEY & LED:

Display	UPPER : 4 Digit 7 Seg 0.70", RED LED LOWER : 4 Digit 7 Seg 0.50", GREEN LED
Key	SET, INC, DEC, LEFT & RIGHT Shift key, ENT

### DIMENSION:

Size	100 (H) x 100 (W) x 70(D) mm
Panel Cutout	92 (H) x 92 (W) mm

### OUTPUT SPECIFICATION:

Relay Output	
Relay	4 Nos.
Relay Type	1 (NO-C-NC)
Rating	5A, 230V AC
RS-485 Modbus	

## AUXILIARY SUPPLY:

Supply voltage	100 To 270V AC,50/60 Hz,
Power consumption (VA RATING)	Approx 4VA @ 230V AC MAX,

## ACCURACY:

Class 1.0 (Standard)
----------------------

## ENVIRONMENT CONDITION:

Operating Temp.	0°C to 55°C
Relative Humidity	UP to 95% RH (non-condensing)
Protection Level (AS Per Request)	IP-65 (Front side) As per IS/IEC 60529 : 2001

## Terminal Diagram

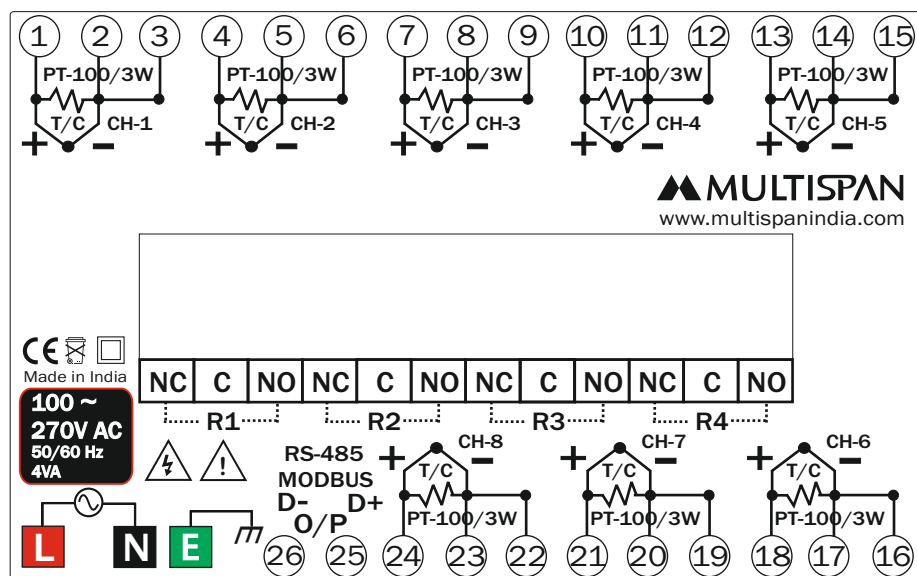

## Key Operation

- \* Press **SET** key to enter in set value menu.
- \* Press **▲** & **▼** key to change the parameter setting.
- \* Press **➤** + **SET** key to enter in parameter menu (Input Selection, skip-unkip selection)
- \* Press **◀** + **SET** key to enter in group menu for relay mode selection.
- \* Press **▲** + **▼** key to set OFFSET.
- \* Press & Hold **➤** key to enter in scroll & hold mode.

## Procedure

- \* Do all connection as per the wiring diagram
- \* To Configure:
  1. Input Selection
  2. Relay Mode
    - If 1 Relay per group LOW
    - If 2 Relay per group LOW/HIGH
    - HIGH
    - HIGH/TRIP
    - HIGH/LOW
  3. Set Point Selection
  4. Offset Setting
  5. RTC Setting

**Note:-** Dp selection for PT-100/3Wire Only.

\* If needed to add offset, Press **▲** + **▼** together.

Set offset for each channel if required.



Offset range will be  $\pm 25^\circ\text{C}$  for J, K, PT-100 temperature input. Offset range will be  $\pm 25.0^\circ\text{C}$  for PT.1 When DP is selected YES.

## Main Menu:

To change set value & hysteresis based on relay mode & grouping

### For Example:

- \* Group No 1 If 1st channel, have a set point as a high alarm, 1 relay
- \* Group No 2 nd channel, have a set point as a low alarm, 1 relay
- For, 3rd, 4th, 5th, 6th, 7th, 8th channel have a set point as high & low alarm, 2 relay

- \* Press & Hold  key for auto scrolling or manual scrolling.
- \* In hold mode use  &  key to select next channel.
- \* If LED is blinking than Alarm is on.
- \* If LED is continuously on Alarm was on.
- \* If LED is off than Alarm is off.
- \* If lower display shows  $\overline{000}$  than it means all Alarms are off for that channel.

### Menu 1 :-

To configurable scan time, Input selection, for individual channel, skip or unskip channel, dp selection

### Menu 2 :-

To configurable no.of channel per group. (User can define maximum 4 group & maximum 8 channel/group), relay mode

### Menu 3 :-

Set Point Selection

### Menu 4 :-

To configurable offset for individual channel, if require.

### Menu 5 :-

Communication : RS-485 Modbus Facility

## MENU-1

Note :- Values can be changed by pressing  or  keys.

### Input Selection

Press  +  key.

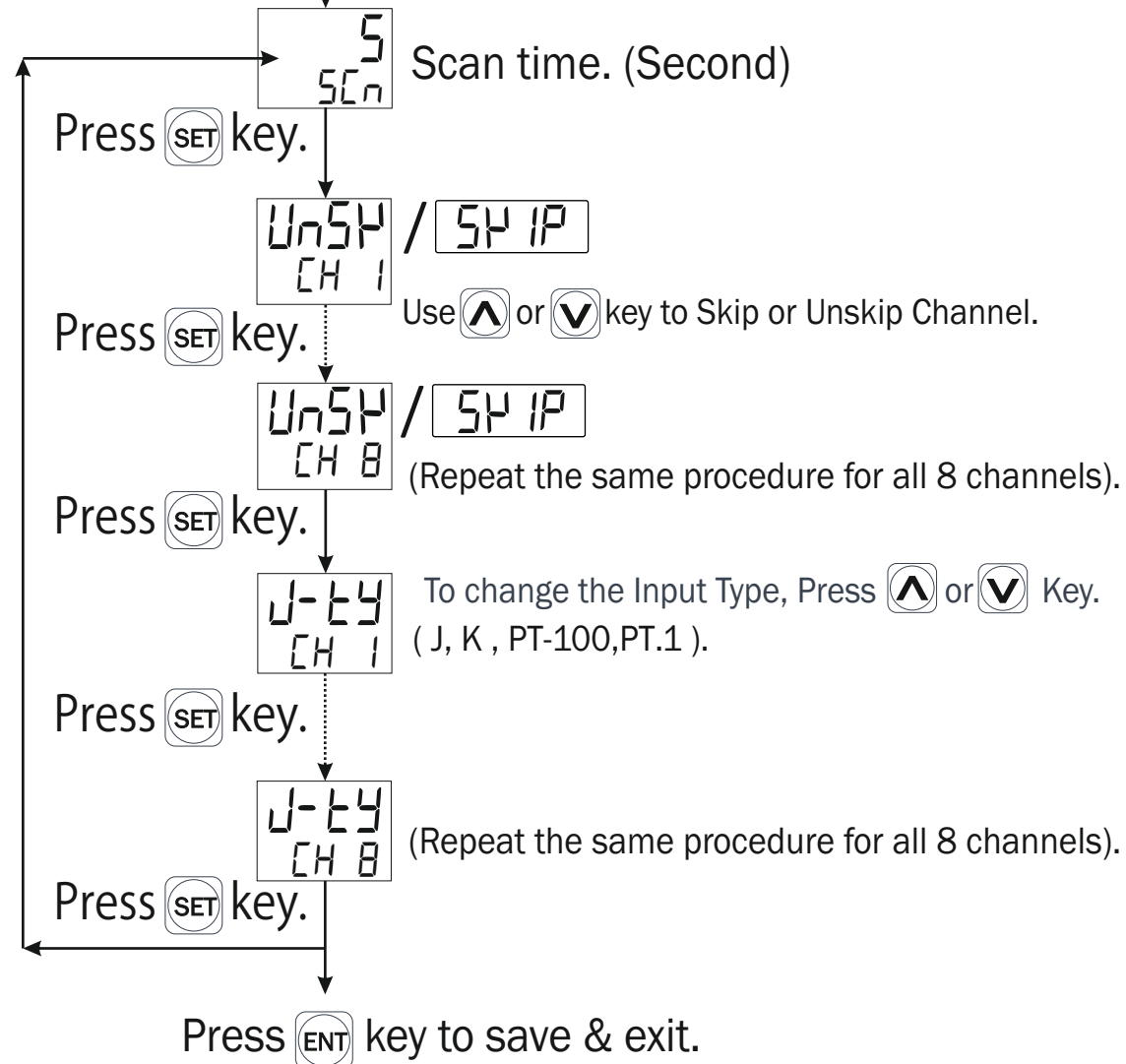

**For Example:**

In Group No 1, If 1st channel, have a set point as a high alarm, 1 relay.  
 In Group No 2 If 2nd channel, have a set point as a low alarm, 1 relay.  
 For, 3rd, 4th, 5th, 6th, 7th, 8th channel have a set point as high & low alarm, 2 relay.

**Menu: 2**

To configurable no.of channel per group. (User can define maximum 4 group & maximum 8 channel/group), relay mode

**Relay menu**

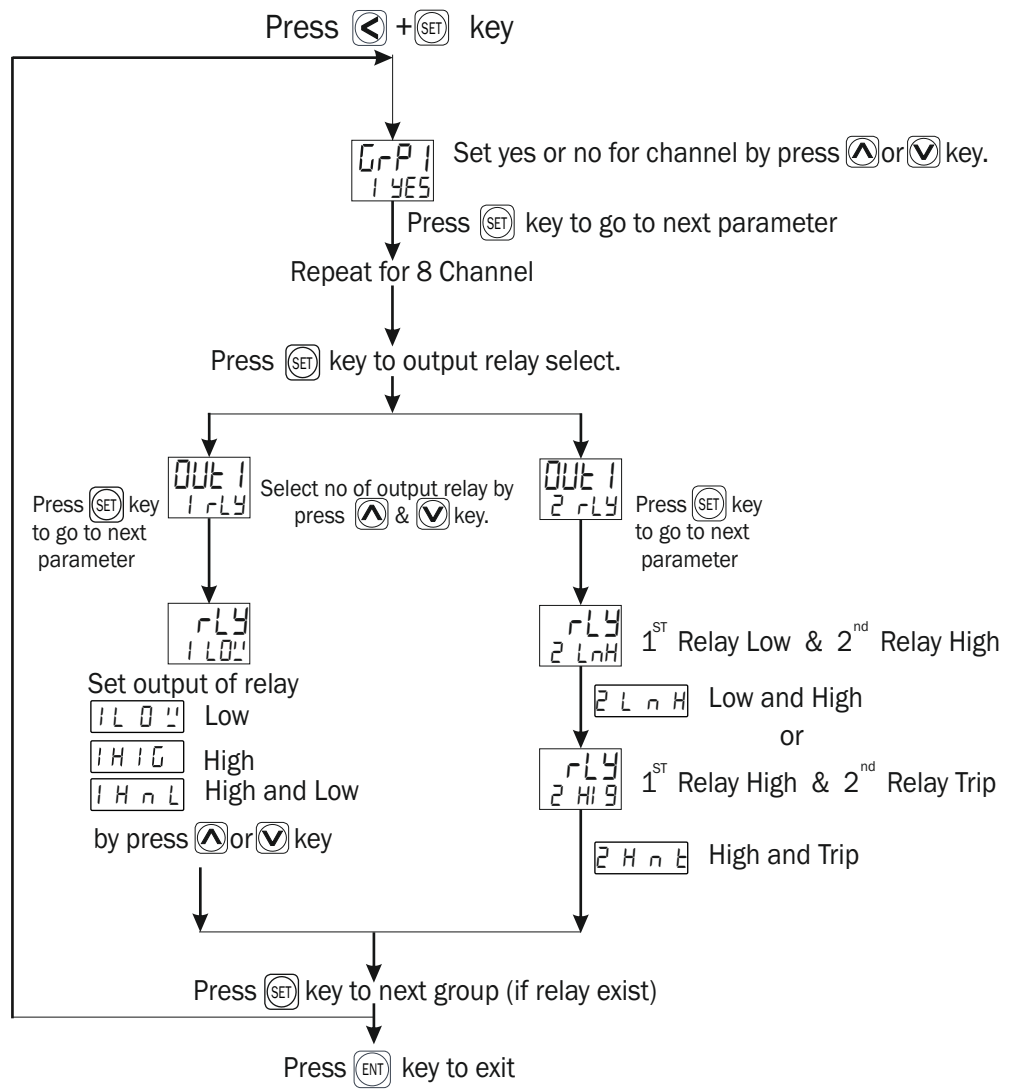

Note: Set value can be changed by <Up> or <Down> key.

Main Menu: To change set value & hysteresis based on relay mode & grouping

**MENU-3**

**Set point Selection**

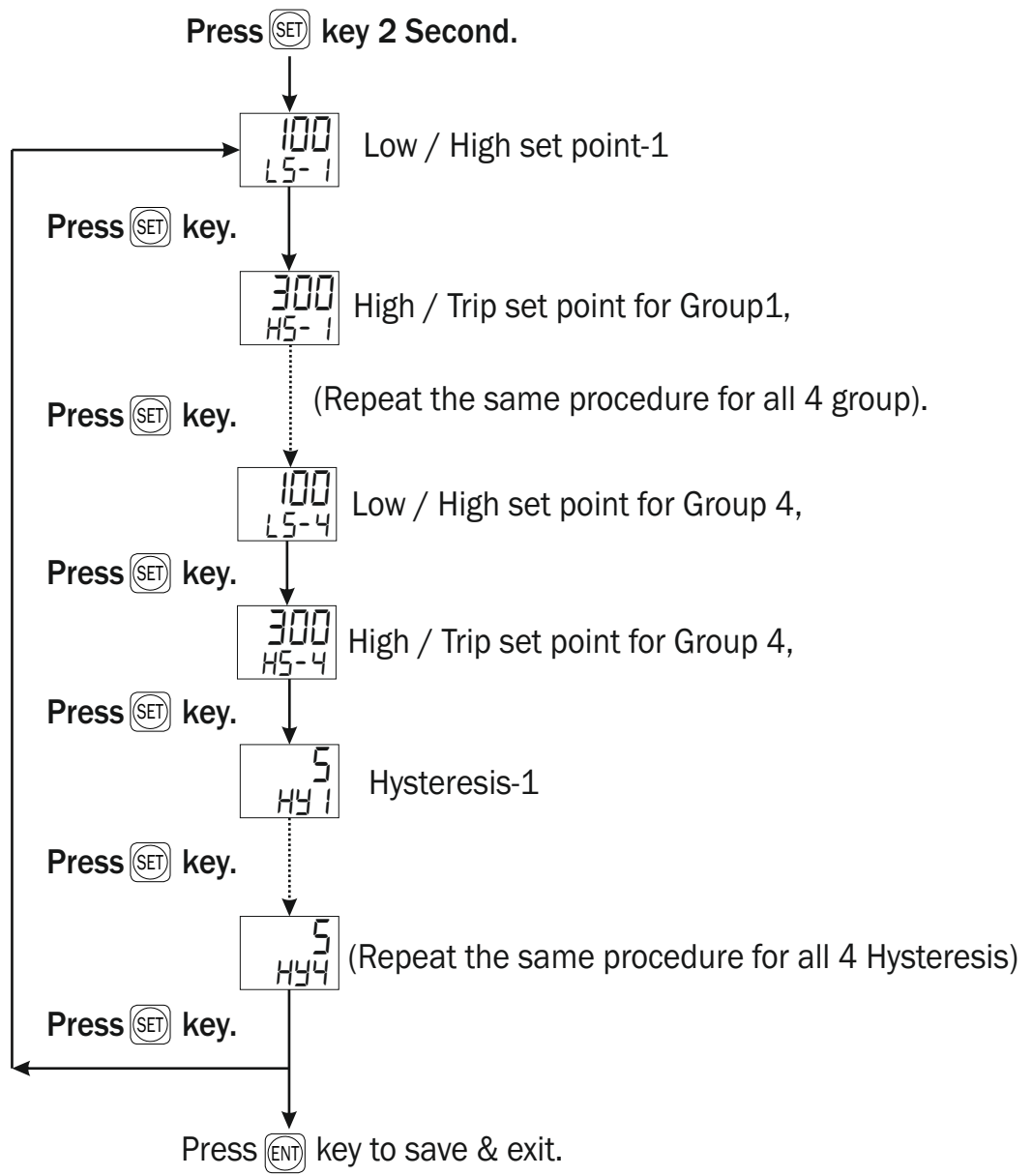

Offset selection

Press  +  key to change offset.

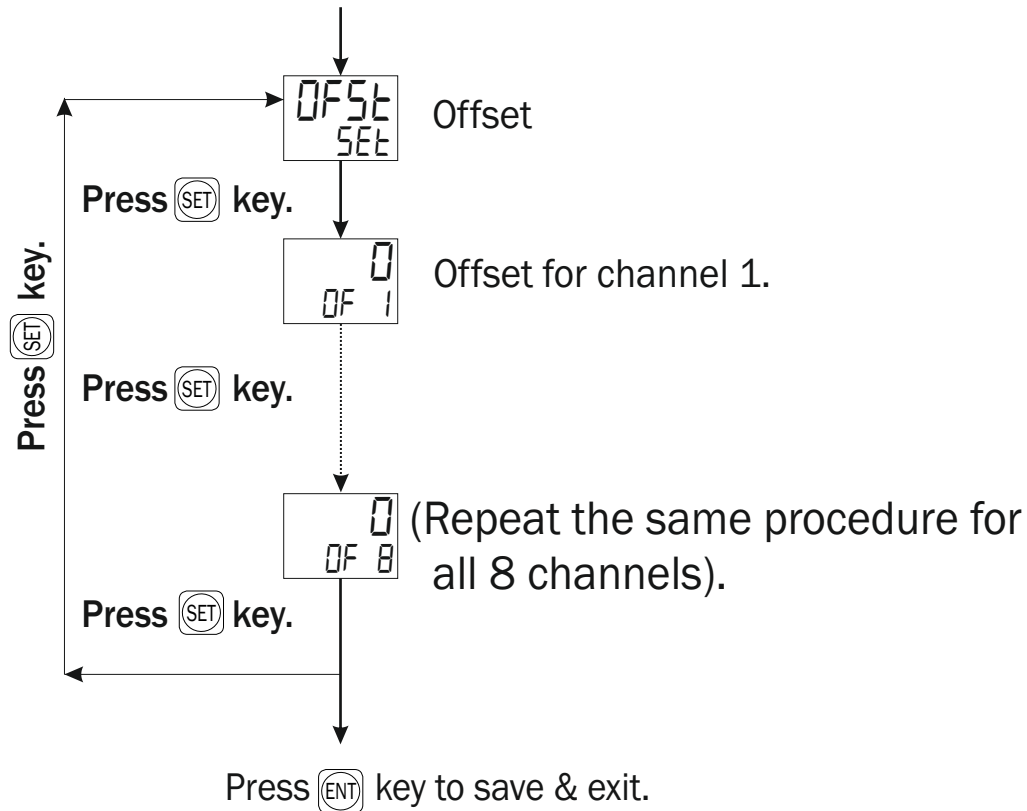
Communication Parameter

Press  &  key to access Communication Parameter.

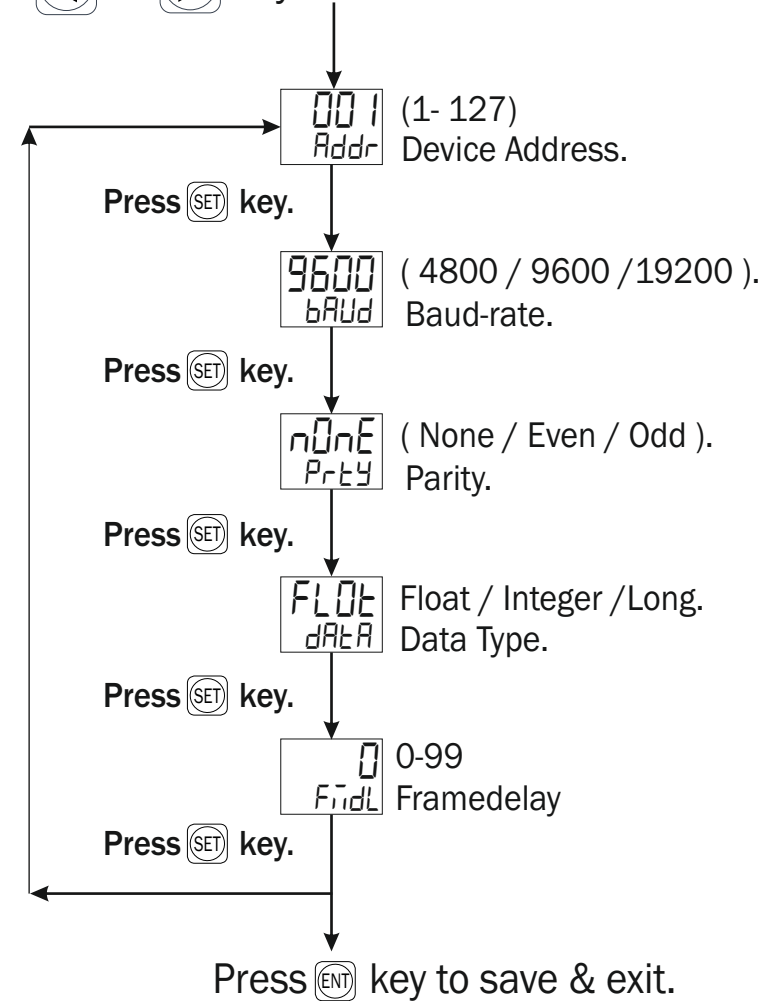

# Mechanical Dimensions & Installation

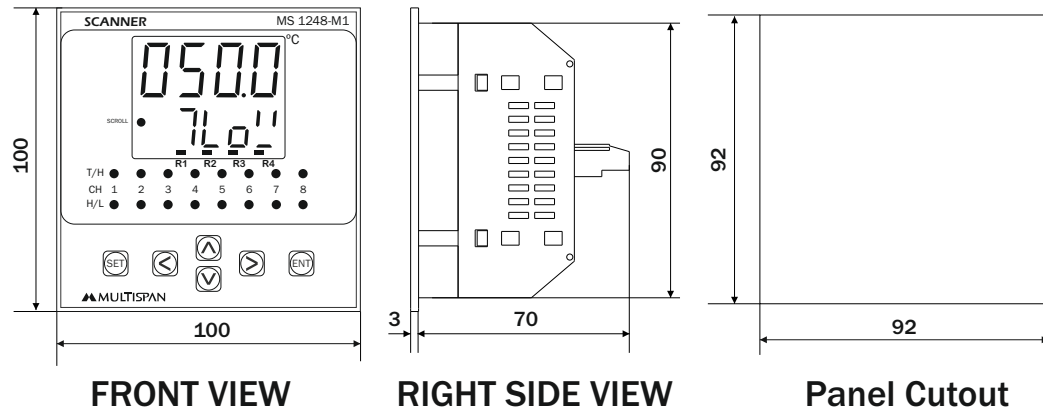

- 1) Prepare the panel cutout with proper dimensions as show above.
- 2) Fit the unit into the panel with the help of clamp given.
- 3) The equipment in its installed state must not come in close proximity to any heating source, caustic vapors, oils steam, or other unwanted process by products.
- 4) Use the specified size of crimp terminal (M3.5 screws) to wire the terminal block. Tightening the screws on the terminal block using the tightening torque of the range of 1 N.m.
- 5) Do not connect anything to unused terminals.

## Safety Precautions



**WARNING : Risk of electric shock.**

- All safety related codifications, symbols and instructions that appear in this operating manual or on the equipment must be strictly followed to ensure the safety of the operating personnel as well as the instrument.
- If all the equipment is not handled in a manner specified by the manufacturer, it might impair the protection provided by the equipment .
- Read complete instructions prior to installation and operation of the unit.

## Warning Guidelines

- To prevent the risk of electric shock power supply to the equipment must be kept OFF while doing the wiring arrangement. Do not touch the terminals while power is being supplied.
- To reduce electro magnetic interference, use wire with adequate rating & twists of the same of equal size shall be made with shortest connection.
- Cable used for connection to power source, must have a cross section of 1mm or greater. These wires should have insulations capacity made of at least 1.5kV.
- A better anti-noise effect can be expected by using standard power supply cable for the instrument.

## Installation Guidelines

- This equipment, being built-in-type, normally becomes a part of main control panel and in such case the terminals do not remain accessible to the end user after installation and internal wiring.
- Do not allow pieces of metal, wire clippings, or fine metallic fillings from installation to enter the product or else it may lead to a safety hazard that may in turn endanger life or cause electrical shock to the operator.
- Circuit breaker or mains switch must be installed between power source and supply terminal to facilitate power 'ON' or 'OFF' function. However this mains switch or circuit breaker must be installed at convenient place normally accessible to the operator.
- Use and store the instrument within the specified ambient temperature & humidity ranges as mentioned in this manual.

## Maintenance

- The equipment should be cleaned regularly to avoid blockage of ventilating parts. Clean the equipment with a clean soft cloth. Do not use isopropyl alcohol or any other cleaning agent. Fusible resistor must not be replaced by operator.

# Modbus Setting

1) Device Address	1 to 127
2) Baud-rate	4800 , 9600 , 19200 (bps)
3) Parity	None , Even , Odd
4) Data Type	Sign Integer , Float, Long
5) Frame Delay	0 to 99

Read/ Write	Parameter		Data Type = Long		Data Type = Sign Integer	
			Read Function Register		Read Function Register	
			0x04	0x03	0x04	0x03
			Address		Address	
R/W	Scan Time		30002	40002	30001	40001
R/W	Skip Channel 1	1- skip channel 2 unskip channel	30004	40004	30002	40002
R/W	Skip Channel 2		30006	40006	30003	40003
R/W	Skip Channel 3		30008	40008	30004	40004
R/W	Skip Channel 4		30010	40010	30005	40005
R/W	Skip Channel 5		30012	40012	30006	40006
R/W	Skip Channel 6		30014	40014	30007	40007
R/W	Skip Channel 7		30016	40016	30008	40008
R/W	Skip Channel 8		30018	40018	30009	40009
R/W	Input Channel 1	1- J Type 2- K Type 3- PT 4- PT.1	30020	40020	30010	40010
R/W	Input Channel 2		30022	40022	30011	40011
R/W	Input Channel 3		30024	40024	30012	40012
R/W	Input Channel 4		30026	40026	30013	40013
R/W	Input Channel 5		30028	40028	30014	40014
R/W	Input Channel 6		30030	40030	30015	40015
R/W	Input Channel 7		30032	40032	30016	40016
R/W	Input Channel 8		30034	40034	30017	40017
R/W	Offset Channel 1		30074	40074	30037	40037
R/W	Offset Channel 2		30076	40076	30038	40038
R/W	Offset Channel 3		30078	40078	30039	40039
R/W	Offset Channel 4		30080	40080	30040	40040
R/W	Offset Channel 5		30082	40082	30041	40041
R/W	Offset Channel 6		30084	40084	30042	40042
R/W	Offset Channel 7		30086	40086	30043	40043
R/W	Offset Channel 8		30088	40088	30044	40044
R/W	Group1 Low Setpoint		30132	40132	30066	40066
R/W	Group1 High Setpoint		30134	40134	30067	40067
R/W	Group2 Low Setpoint		30136	40136	30068	40068
R/W	Group2 High Setpoint		30138	40138	30069	40069
R/W	Group3 Low Setpoint		30140	40140	30070	40070
R/W	Group3 High Setpoint		30142	40142	30071	40071
R/W	Group4 Low Setpoint		30144	40144	30072	40072
R/W	Group4 High Setpoint		30146	40146	30073	40073
R/W	Hysteresis 1		30148	40148	30074	40074
R/W	Hysteresis 2		30150	40150	30075	40075
R/W	Hysteresis 3		30152	40152	30076	40076
R/W	Hysteresis 4		30154	40154	30077	40077
R/W	Address		30164	40164	30082	40082
R/W	Baudrate	1-4800, 2-9600, 3-19200	30166	40166	30083	40083
R/W	Parity	1-none, 2-even, 3-odd	30168	40168	30084	40084
R/W	Datatype	1-integer, 2-long, 3-float	30170	40170	30085	40085
R/W	Frame Delay	0 TO 99	30172	40172	30086	40086
R/W	USB Time		30176	40176	30088	40088
R/W	USB Time Unit	1-second, 2-minute	30178	40178	30089	40089
R	PV Channel 1	18000-chnnel skip 15000-open 16000-over 17000-low	30222	40222	30111	40111
R	PV Channel 2		30224	40224	30112	40112
R	PV Channel 3		30226	40226	30113	40113
R	PV Channel 4		30228	40228	30114	40114
R	PV Channel 5		30230	40230	30115	40115
R	PV Channel 6		30232	40232	30116	40116
R	PV Channel 7		30234	40234	30117	40117
R	PV Channel 8		30236	40236	30118	40118
R	Alarm Channel 1	0-Normal Single Relay	30242	40242	30121	40121
R	Alarm Channel 2	1-low alarm triggered	30244	40244	30122	40122
R	Alarm Channel 3	3-High alarm triggered	30246	40246	30123	40123
R	Alarm Channel 4	5-HnL low alarm triggered 7-HnL high alarm triggered	30248	40248	30124	40124
R	Alarm Channel 5	Double Relay	30250	40250	30125	40125
R	Alarm Channel 6	9-LH low alarm triggered	30252	40252	30126	40126
R	Alarm Channel 7	11-LH high alarm triggered	30254	40254	30127	40127
R	Alarm Channel 8	13-HT high alarm triggered 15-HT trip alarm triggered	30256	40256	30128	40128
R						
R	Relay1 Status	1-Relay on 0-Relay off	30262	40262	30131	40131
R	Relay2 Status		30264	40264	30132	40132
R	Relay3 Status		30266	40266	30133	40133
R	Relay4 Status		30268	40268	30134	40134